



Undercounter, Prep Table and Pizza Prep Table Operator's Manual



Please read these instructions completely before operating the units.

Please read this manual carefully before installing and operating the unit. Keep this manual handy for future reference.

This series of equipment is intended for use in rooms where the environmental conditions are controlled and maintained such that the ambient temperature typically does not exceed 86 F.

Main technical data:

RATED VOLTAGE (V)	115
RATED FREQUENCY(Hz)	60
TEMP RANGE	Refrigerator: 34~47 °F ; Freezer: 0~-8 °F

Important Safety Instructions:

Please read instructions before using this equipment:

- This appliance must be properly installed according to instructions before use. Failure to comply can void warranty.
- Leave adequate space from the wall to the cabinet and ceiling for proper air circulation. Remove the protective film completely. The unit requires at least 20 cm from cabinet to the wall and ceiling. Do not install near heat or direct sunlight. Ensure ventilation openings are not obstructed.
- Avoid damage to unit or forcible impact or inclining unit beyond 45 degrees due to presence of R290 refrigerant. We cannot be held liable for defects or issues arising from improper handling or transportation of the equipment.
- If the unit is inclined more than 45 degrees, leave unplugged for 24 hours after it is returned to a fully upright position.
- Remove all packaging from the bottom of the unit to avoid fire.
- Do not store flammable products or chemicals near the unit due to the risk of explosion.
- Ensure that rated voltage corresponds to electrical system at location. Do not connect grounding wire to a water or gas pipe. Power plug should have own outlet and not be used with adapters or extension cords. Do not run power cable under carpeting or runners. Arrange power cable away from high traffic areas to avoid a potential tripping hazard.
- Children should not play in or around the appliance.
- If the power cable is damaged, please notify a certified service technician.
- Make sure to unplug the unit when cleaning or maintaining it. Turn switch to "OFF" and remove plug from outlet. Do not disconnect by tugging on power cable or touching with wet hands.
- This appliance is for indoor use only.
- Do not splash water on the appliance as it can cause electric shock or problems with unit.
- If the unit is a freezer, when it is in operation do not touch the cold surface with wet or damp hands as skin may adhere.
- If the unit is a freezer, never place glass inside it as it can explode when under pressure.
- Do not store explosive substances (i.e., aerosol products) in the unit. Risk of explosion.
- The R290 refrigerant and insulation require special disposal procedures. Please consult a certified service technician prior to disposing of the unit.
- Do not damage the refrigeration circuit. Failure to comply can void warranty.
- Do not use any mechanical device to speed up the defrosting process. Failure to comply can void warranty.
- Only certified service technicians shall repair or alter the unit. Failure to comply can void warranty.

Use of Equipment & Maintenance:

Start up: Before operating your unit, please be sure that all casters are properly installed. **Unit must be level.** This helps to ensure proper door alignment, adequate drainage and proper overall system operation. Ensuring that the unit is level is the responsibility of the end user. Power to the unit is generated immediately after plugging in the power cable to the appropriate outlet.

Set Temperature: Push the SET key for more than 2 seconds to change set point value; the value of the set point will be displayed and the "C" or "F" LED starts blinking. To change set value, push the arrows within 10 seconds. To memorize the new set point value, push the SET key again or wait 10 seconds.

Temperature Controller: After turning on, there will be a delay time of approximately 2 minutes before the compressor starts. To protect the compressor, it can re-start unless the time when the compressor stops every time is longer than the delay time (2 minutes). CAUTION: Setting the temperature control to the coldest setting will require parameter adjustments by a certified service technician.

Glacier products have been set at the factory. Do not modify the thermostat parameters on the unit yourself, or you may cause damage to the compressor or other components

Storage: Do not throw food or cans into the cabinet. It will damage the sides/doors. Do not overcrowd the unit with product. Proper air circulation is necessary for optimal operation.

Maintenance: The life of your equipment can be maintained by proper cleaning and care.

Cleaning: Regular cleaning of the unit is expected each month or when spills occur. Disconnect power to the equipment prior to initiating any cleaning or repairs. Use a soft cloth and mild detergent and polish with a clean, soft cloth for optimal results. Avoid abrasive cleaning products. When cleaning inside the cabinet, be sure to use mild detergent that is safe for food.

Cleaning the condenser: We recommend cleaning the condenser regularly to ensure optimal operation of the unit. Use a vacuum cleaner or dry brush.

Restart: Wait 5 minutes before plugging unit back in.

Timing of defrost: The electronic control panel is pre-set to automatically execute 4 defrosting cycles ever 24 hours. To modify defrost start to a desired time, press DEFROST button for 6 seconds. The unit will start the defrost cycle. The next defrost cycle will follow 6 hours later.

Manual defrosting: Press the button on the top right of the thermostat controller display for 6 seconds. The defrost will start once the sensor detects a temperature inferior to the preset value. In this phase, the defrosting light and defrost LED will display. Freezer coils are defrosted electronically. Refrigeration coils are defrosted by the compressor stopping. CAUTION: Do not remove ice with a sharp metal instrument as this will cause damage to the unit.

ATTENTION!

The following are normal and do not indicate a problem with the unit:

- A light sound of water flow in the cabinet
- Heat from the compressor or condenser
- Water drops outside the doors – this is due to high ambient humidity and the water should be wiped away

CIRCUIT DIAGRAM FOR UNDER COUNTER FREEZER

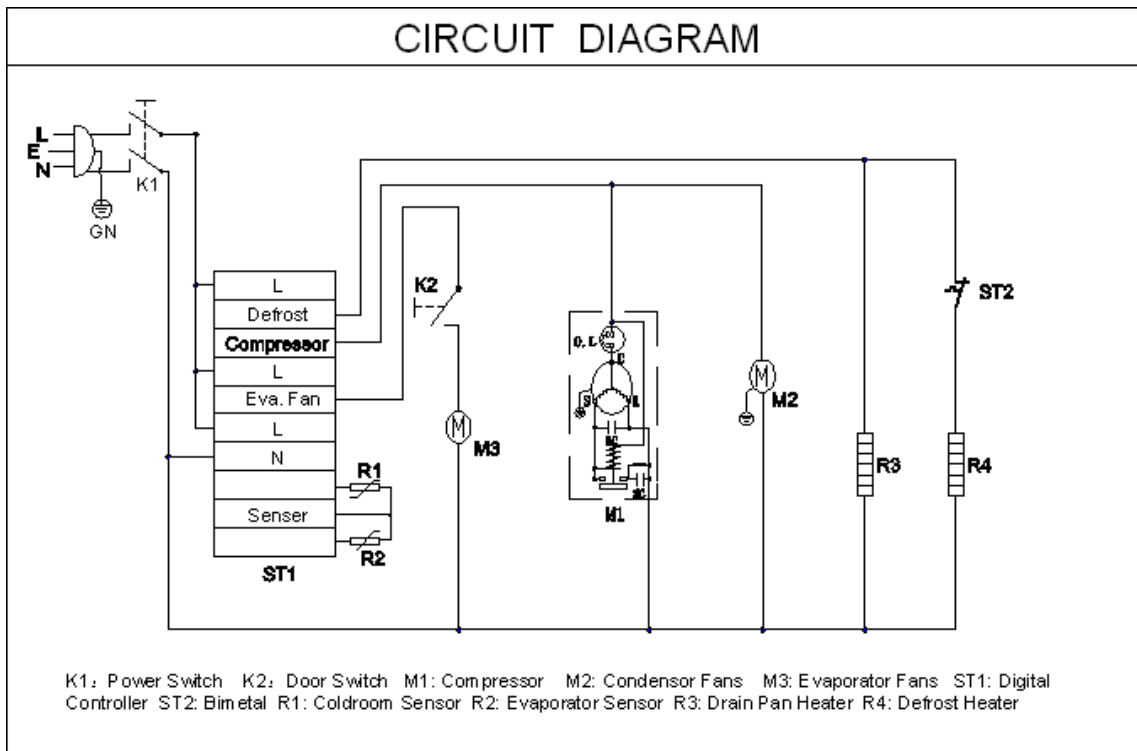

CIRCUIT DIAGRAM FOR UNDER COUNTER REFRIGERATOR, SALAD PREPS AND PIZZA PREPS

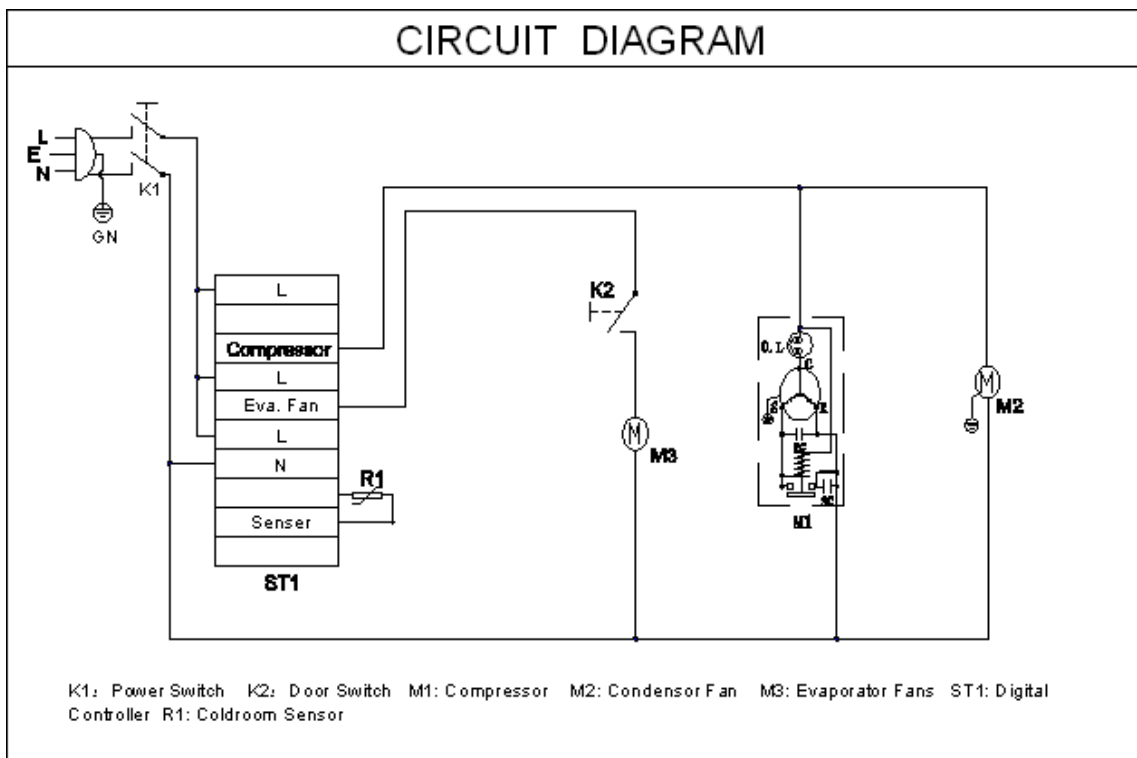

Technical parameters:

Model	Temp.	Climatic Category:	Refrigerant	Net Weight kg/lb	Rate Current A	Input Power W	Energy Consumption kWh/24h
GUR-29	34~47°F	4/5	R290	72/158	2	225	1.14
GUR-48	34~47°F	4/5	R290	96/211	2.4	280	1.6
GUR-60	34~47°F	4/5	R290	105/231	2.4	280	1.8
GUR-72	34~47°F	4/5	R290	110/242	3.4	380	2
GST-29-8	34~47°F	4/5	R290	92/202	2	225	1.6
GST-48-12	34~47°F	4/5	R290	105/231	2.4	280	1.8
GST-60-16	34~47°F	4/5	R290	125/341	2.4	280	2
GST-72-18	34~47°F	4/5	R290	155/341	3.4	380	2.3
GUF-29	0~-8°F	4/5	R290	72/158	2.3	560	3.2
GUF-48	0~-8°F	4/5	R290	96/211	8	660	4.5
GUF-60	0~-8°F	4/5	R290	105/231	8	900	5.3
GUF-72	0~-8°F	4/5	R290	110/242	12.4	1050	6.1
GPP-44	34~47°F	4/5	R290	102/224	2.2	250	2.57
GPP-70	34~47°F	4/5	R290	135/297	2.8	308	5.1
GPP-90	34~47°F	4/5	R290	192/423	8.5	613	6.04

Glacier 2 Year Warranty

All claims for parts or labour must be made directly through Glacier. All claims must include model number of the unit, the serial number, proof of purchase, date of purchase and all appropriate information supporting the alleged defect.

In case of compressor replacement under warranty, either compressor or compressor tag must be returned to Glacier along with the above information. Failure to comply with warranty policies will result in voiding claims.

Two-Year Parts & Labour Warranty

Glacier warrants all new refrigerated components, such as the cabinet and all parts, to be free from defects in materials or workmanship. Glacier's obligation under this warranty is limited to a period of two years from the date of original purchase. It is limited to repair or replacement as determined by Glacier. The labour warranty shall include standard straight time labour charges only and travel time only within 100 kilometres of an authorized service technician.

Additional Three-Year Compressor Warranty

In addition to the two-year warranty stated above, Glacier warrants its sealed compressor to be free from defects in both material and workmanship under normal and proper use and maintenance service for a period of three additional years from the date of original purchase, but not to exceed 5 years. Compressors that have been determined by Glacier to be defective within this extended period will be either repaired or replaced with a compressor or compressor parts of similar design and capacity according to Glacier's discretion. The three-year extended compressor warranty applies only to sealed parts of the compressor and does not apply to any other parts or components. This includes: the cabinet, paint finish, temperature control, refrigerant, metering device, motor starting equipment, fan assembly, and other electric components, etc.

What is Not Covered by Warranty

Glacier's sole obligation under this warranty is limited to either repair or replacement of parts, subject to the additional limitations below. This warranty neither assumes nor authorizes any person to assume obligations other than those expressly covered by this warranty.

NO CONSEQUENTIAL DAMAGES: GLACIER IS NOT RESPONSIBLE FOR ECONOMIC LOSS; PROFIT LOSS; SPECIAL, INDIRECT, OR CONSEQUENTIAL DAMAGES, INCLUDING WITHOUT LIMITATION, LOSSES, OR DAMAGES ARISING FROM FOOD OR PRODUCT SPOILAGE, REGARDLESS OF WHETHER OR NOT THEY RESULT FROM REFRIGERATION FAILURE.

Warranty is Not Transferable: This warranty is not assignable and applies only in favour of the original purchaser/user of the unit. Any such assignment or transfer shall void the warranties herein and shall void all warranties, express or implied, including any warranty of merchantability or labour coverage for component failure or other that the warranty packet provided with the unit.

Alteration, neglect, abuse, misuse, accident, damage during transit or installation, fire, flood, or acts of God:

Glacier is not responsible for the repair or replacement of any parts that are determined to have been subjected after date of manufacture to alteration, neglect, abuse, misuse, damage during transit or installation, fire, flood, or acts of God.

Improper electrical connections:

Glacier is not responsible for the repair or replacement of failed or damaged components resulting from electrical power failure, low voltage, the use of extension cords for voltage drops to the unit. The two year parts and labour warranty and the additional three-year compressor warranty is as described above. These warranties include implied warranty and merchantability or fitness for a particular purpose. There are no warranties which extend beyond the description on the face hereof.

Outside Canada and the United States:

This warranty does not apply to areas outside of Canada or the continental United States. Glacier is not responsible for any warranty claims made on products sold or used in such areas.

*Glacier may at any time modify our equipment to provide and ensure a high-level product.

Please call +1 905-339-5119 ext.4 or go to our website www.ricciogroup.com and go to the "Request Service" tab