

GR-2

Two Door Reach-In Refrigerator

Glacier reach-in refrigerators are built to meet the needs of any foodservice application, delivering top performance without sacrificing style. The sleek design features recessed door handles, ensuring a comfortable grip and making it easy to wipe away food, grease and bacteria. A bottom-mounted compressor ensures efficient cooling, while digital controls let you adjust the temperature precisely. Self-closing doors and auto-defrosting help save energy and maintain temperature, while adjustable shelves and swivel casters make maintenance a breeze.



Features

- Coved corners for easy cleaning
- Recessed door handle and door locks
- Self-closing doors with 90° stay open feature
- Digital temperature controls with LED display
- 4" casters with locks on front
- 8 adjustable and removable wire shelves
- Fits 18" x 26" sheet pans
- 2-year parts and labour warranty
- 5-year compressor warranty

Technical Specifications

- Stainless steel exterior finish
- Stainless steel interior finish
- 115 V/60 Hz
- R290 refrigerant
- Automatic defrost

Optional Features/Accessories

- Additional shelves available for purchase
- 3" casters available for purchase

GR-2

Two Door Reach-In Refrigerator

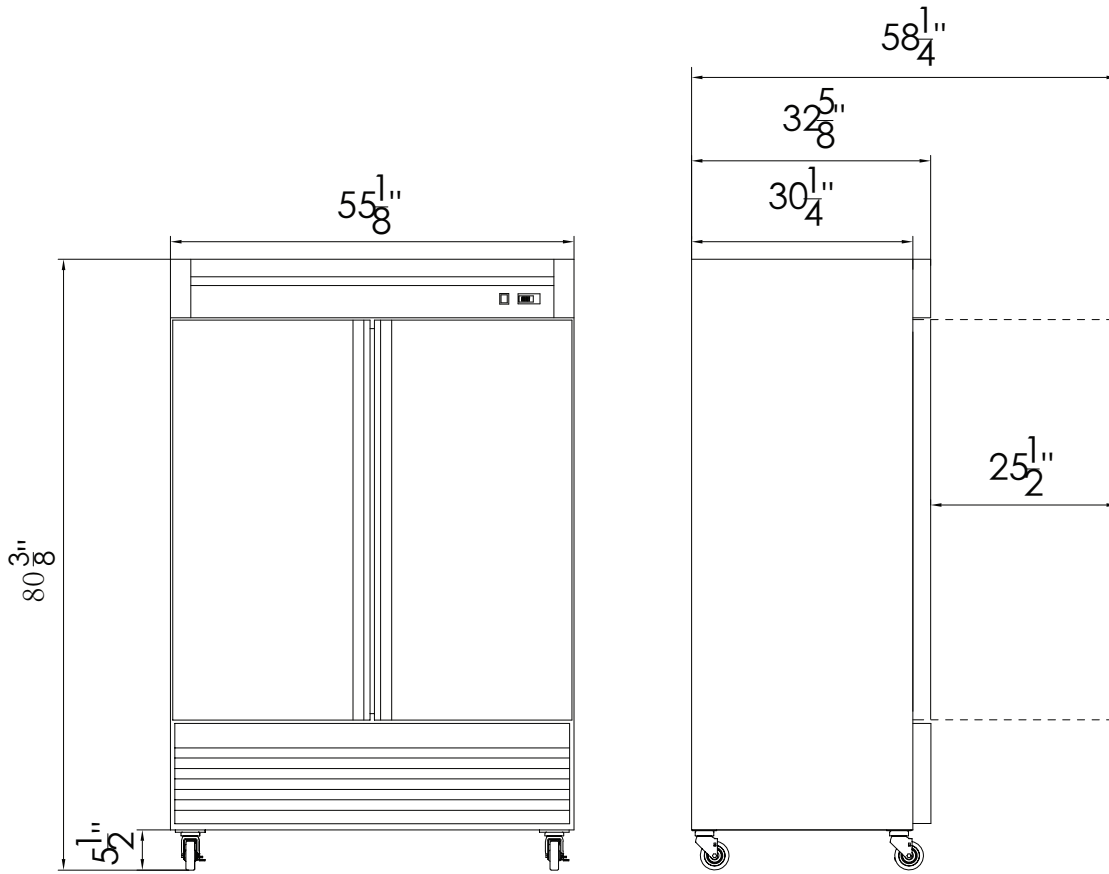

FRONT

LEFT

Model	External Dimensions (inches)			Crated Dimensions (inches)			Temperature Range °F	Compressor Power (HP)	Net Weight	Gross Weight	# of Shelves	NEMA Config.	Amps
	W	D	H	W	D	H							
GR-2	55 1/8	32 5/8	80 3/8	56 3/4	34 1/4	84 5/8	33 ~ 41°F	1/2	463	528	8	5-15P	7.4

Specifications are subject to change without notice.